

LightSync Digital

Ceiling Occupancy Sensor

Overview

The LightSync Digital Occupancy Sensor is a low profile ceiling mount sensor designed to install in a standard commercial ceiling. The sensor is provided with dual-tech operation with passive Infrared and overlapping passive acoustic sensing. Configured over the LightSync digital bus for easy set-up and adjustment, this sensor supports occupancy and vacancy in a single device. The occupancy sensor also has a full range photo sensor supporting open loop or closed loop daylight dimming. The LS digital occupancy sensor uses the newest digital components and detection techniques for superior performance. Sensors detect occupant movement as they move through the field of view via passive infrared technology. Acoustic technology enables enhanced detection once the lighting is turned on.



Features

- Made in the USA
- Low profile ceiling mount dual-tech occupancy and vacancy sensor
- Field configurable for PIR or acoustic sensing operation
- Sensitivity adjustments for passive infrared and acoustic can be independently adjusted to three different levels
- Automatic Gain Control filters background noise to fine tune acoustic sensitivity
- Field configured setting for "no touch" adjustment are all done from the ILC LightLEEDer Pro software
- Dual tech operation is triggered by PIR and uses the acoustic for holding a On state
- Cat-5 ready digitally addressable device
- LED indicators and acoustic sensing can be independently disabled
- Connects directly to a LightLEEDer panel or LLEVO local bus as a LightSync digital device for power and communication, no external power pack required
- Panel level configuration for relay on/off and dimmer control to the local panel or over the ILC network
- Provides control for Relays, Presets, Groups, and Scenes
- Built in selectable photo sensor for full range continuous daylight dimming control
- Auxiliary Relay output for connection to BAS system or Plug-load power pack

Warranty

Five-year limited warranty

Ordering

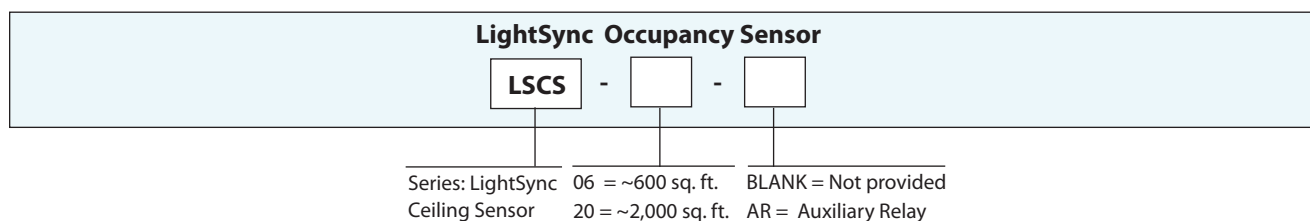

LightSync Digital

Ceiling Occupancy Sensor

Physical

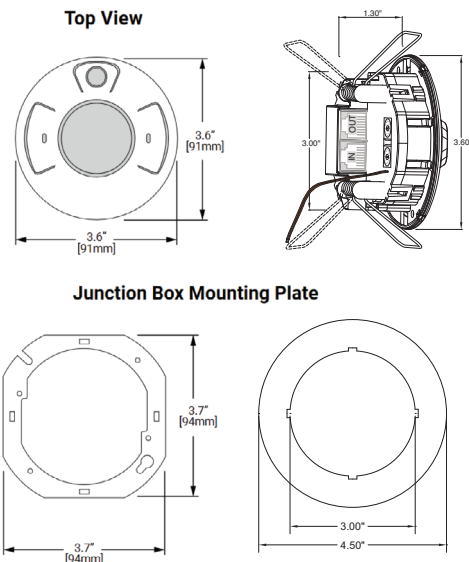

Designed to be installed into ceiling tile with spring clips or onto junction box with trim ring cover

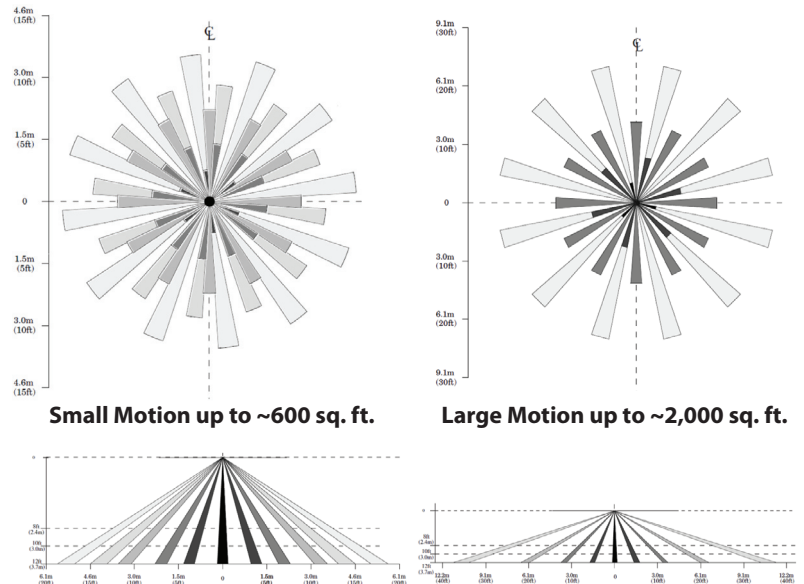

8 feet to 15 feet mounting height recommended for small and large motion lenses, coverage pattern pending validation

Specifications

Physical:

- 3.6"W x 3.6H x 1.4D (91mm x 91mm x 36mm)
- Low profile recessed ceiling mounting
- Spring retention clips for mounting in 3" hole
- Junction box mounted plate and trim ring provided
- RJ-45 In/Out ports
- Digital addressing switches
- 2-Wire #20AWG leads for auxiliary relay output

Operation:

- Selectable PIR or Dual Tech operation from the LightLEEDer panel or LightLEEDer Pro software
- Time Delay is set from LightLEEDer panel software
- Photo sensor for daylight dimming control configured from LightLEEDer software
- An initial PIR event is required to enable acoustic functionality
- Acoustic sensing overlaps and enhances/extends overall detection and time delay
- Automatic gain control filters ambient noise
- Sensor will re-trigger with acoustic only after an initial 5 minute time-out before a PIR trigger is required to restart the cycle
- Daylight Harvesting photocell sensor can be enabled for true full-range control with 0-255 step resolution in the 0 to 1,800 fc range
- Supports all standard ILC photocell sensor control options
- AR Option provides a auxiliary relay for BAS or plug-load power pack operation

Electrical:

- Powered from the ILC LightSync bus
- Auxiliary relay option supports a 2Amp, 30VDC, NO or NC contact output

Operating Environment:

- Location: Interior space
- Operating Temp: 0° to 40° C (32°F to 104°F)
- Humidity: 10% - 90% Non-condensing
- Atmosphere: Non-explosive/corrosive
- Vibration: Stationary

Certifications and Approvals:

- Class 2 inputs
- FCC Part 15
- Meets local energy codes